



TU Clausthal



# *Drilling Simulator in Celle*

## *Simulate, but what?*

PD Dr. Dr-Ing. habil C. Teodoriu

Clausthal University  
Institute of Petroleum Engineering

**Hannover, Oct. 16, 2014**

## *Shell RTOC history*

- 2001 – Shell and Halliburton launched a pilot program using real-data from rigs in the Gulf of Mexico. Target: optimize the drilling process by identifying the variations between PLANNED parameters and REALITY.

*RTOC – Real Time Operation Center*

## Shell RTOC – New Orleans



### Vision:

- Provide State-of-the-art well visualization
- Efficiently drill and complete wells
- Achieve lowest unit technical cost (UTC)

### Achievements:

- 17% reduction in trouble time during 2003
- RTOC savings exceeds investment
- Global Reach



## *Drilling Simulator in Celle - Overview*

- Drilling Simulator Unit (DSU)
- Flow Loop Unit (FLU)
- Drilling Autoclave Systems (DAS)





# Drilling Simulator Unit (DSU)

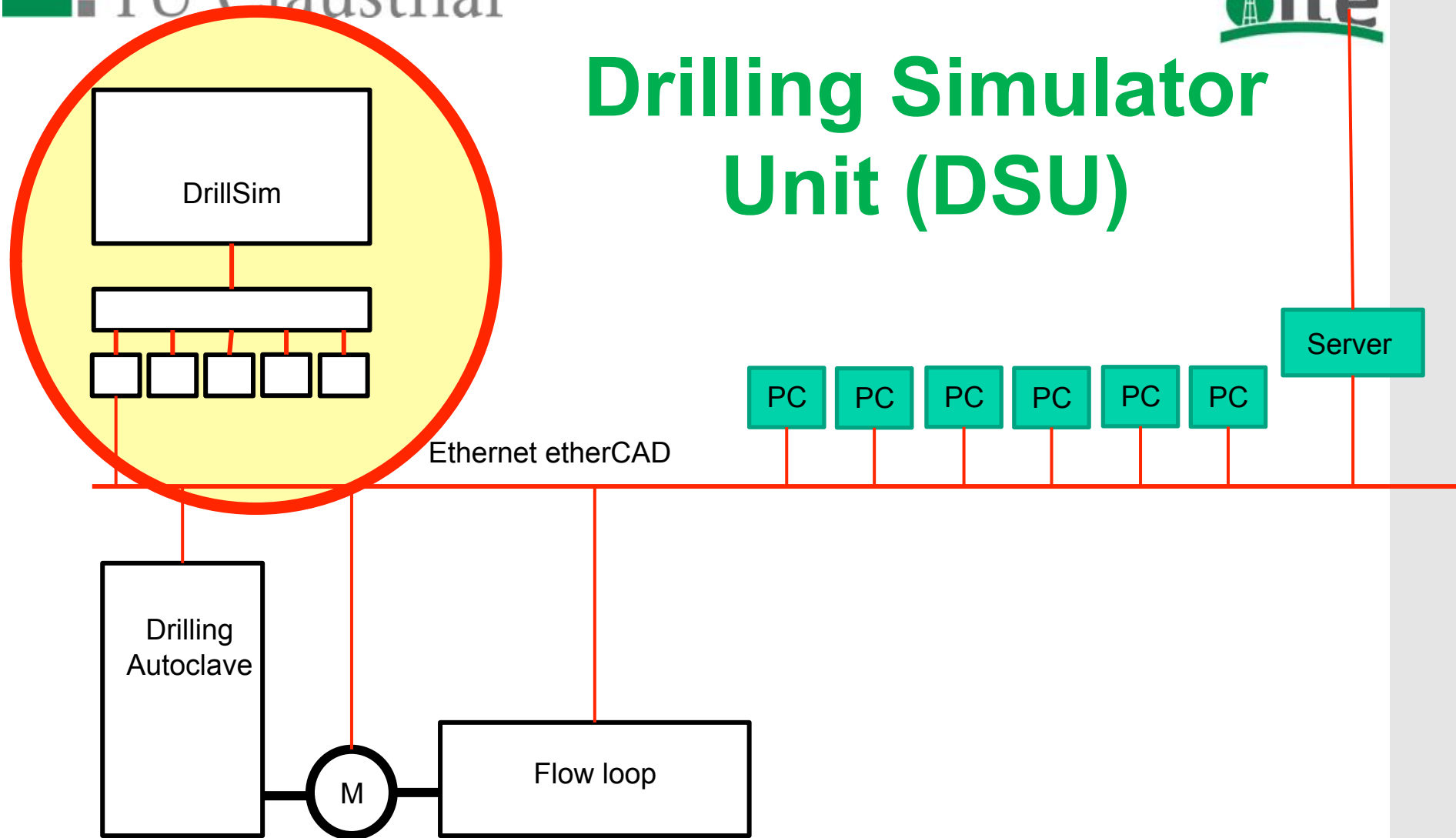

## Drilling HIL Simulator from NOV

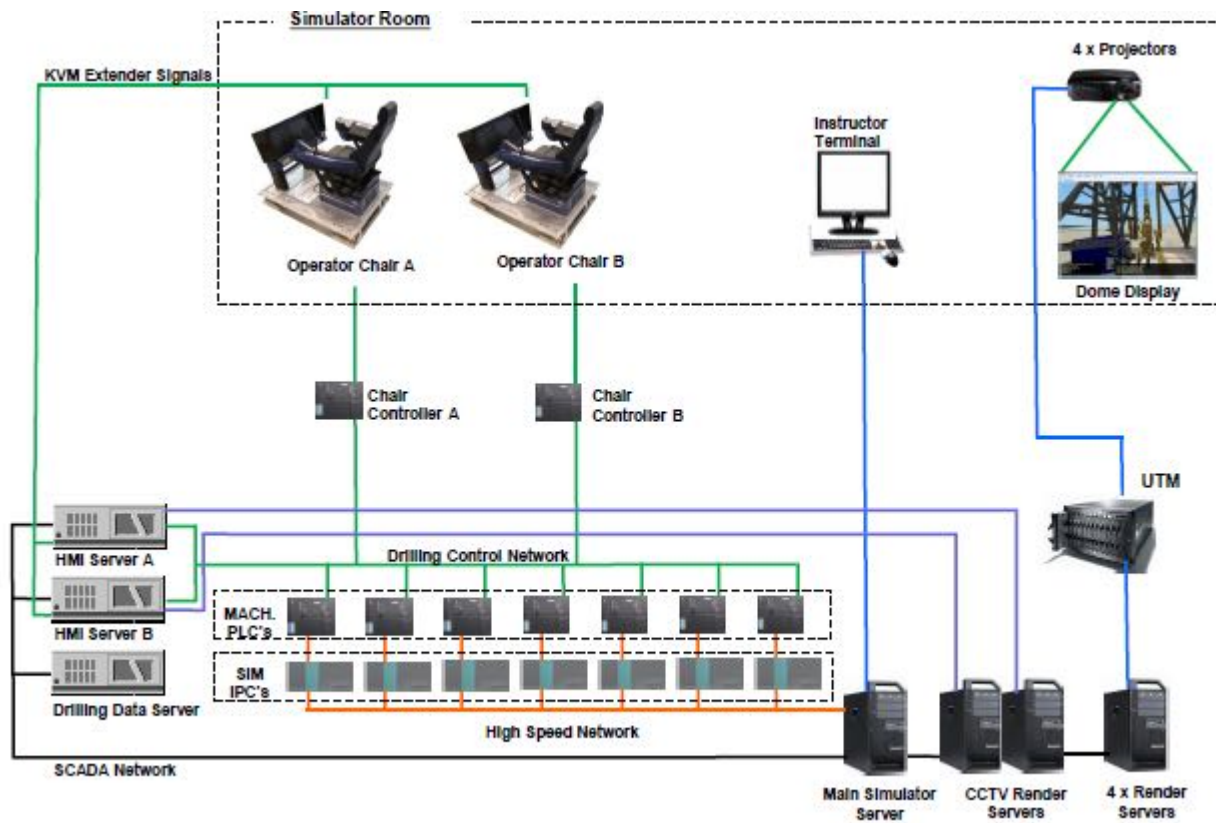

## *Drilling Simulators – between Software and Hardware*



## *Drilling Simulator in Celle – 1*

- Based on DrillSIM-600 with CyberChair
- Combined with extensive and state of the art hardware integration:
  - Flow Loop
  - Drilling Autoclave





## Drilling Simulator in Celle - 2

- Research level implementation has been negotiated.
- Option to communicate with real hardware through I/O module of DS

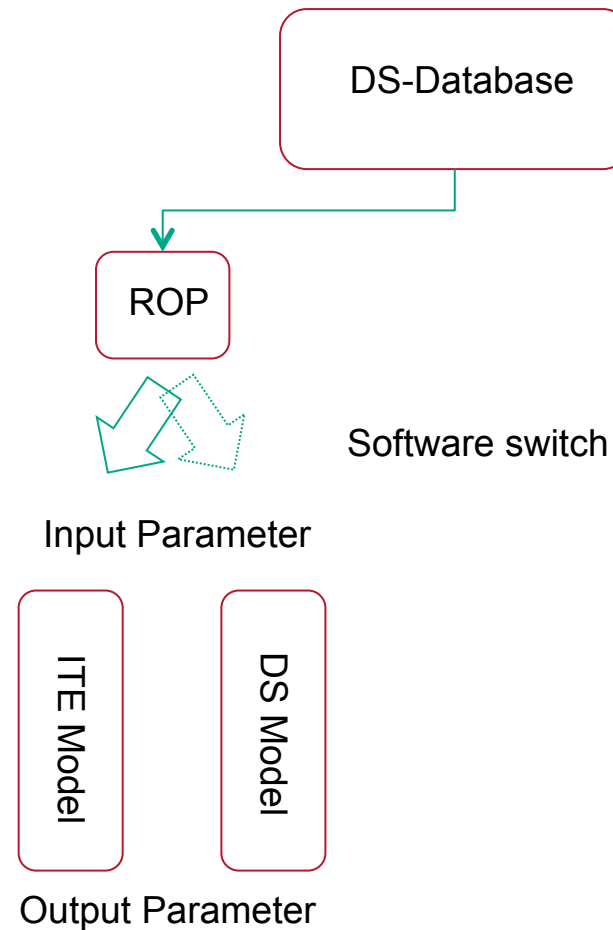

Dateneingabe  
Auswertungs-  
technik

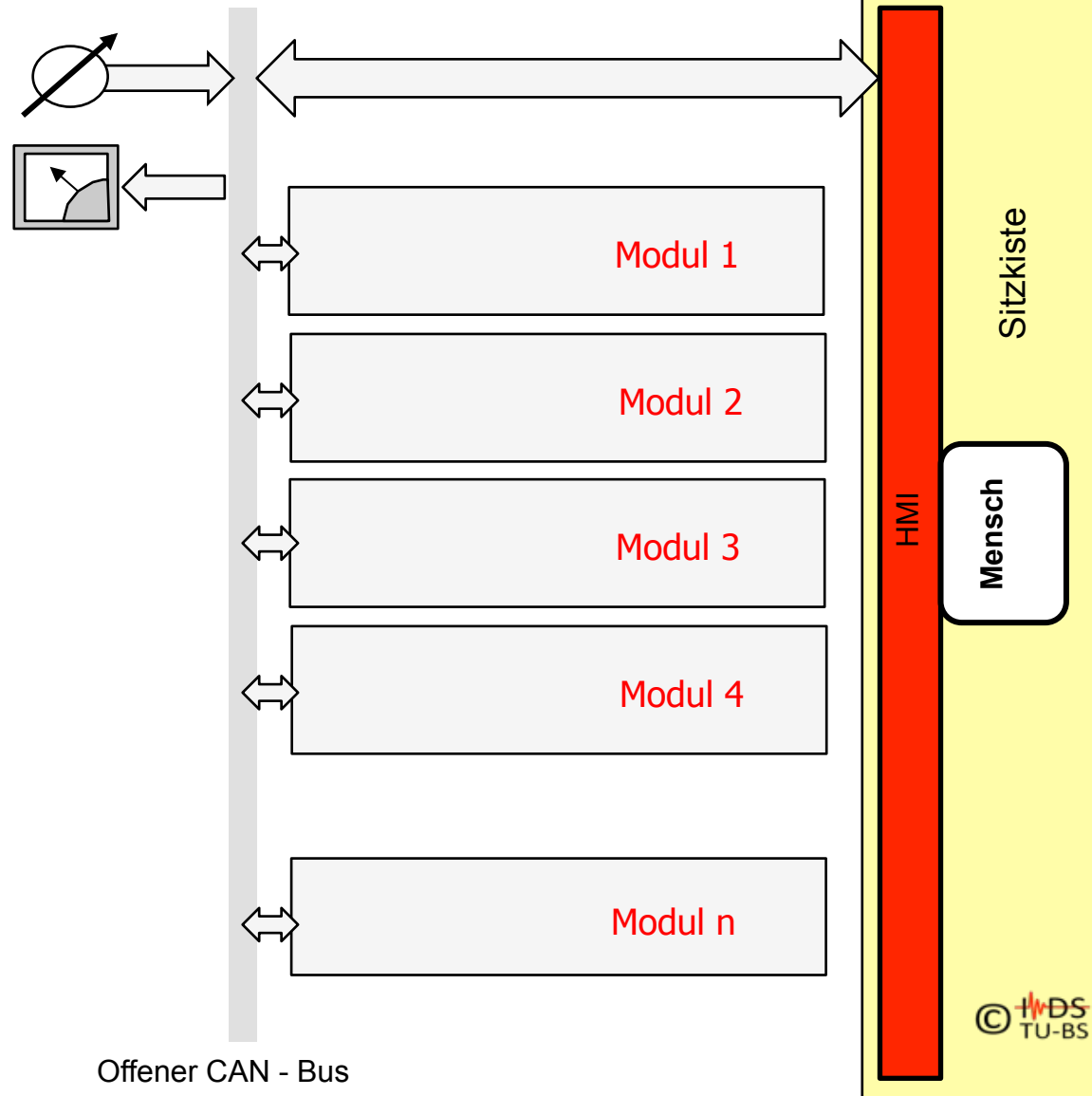

Offener CAN - Bus



Dateneingabe

Auswertungs-  
technik

### Research Option:

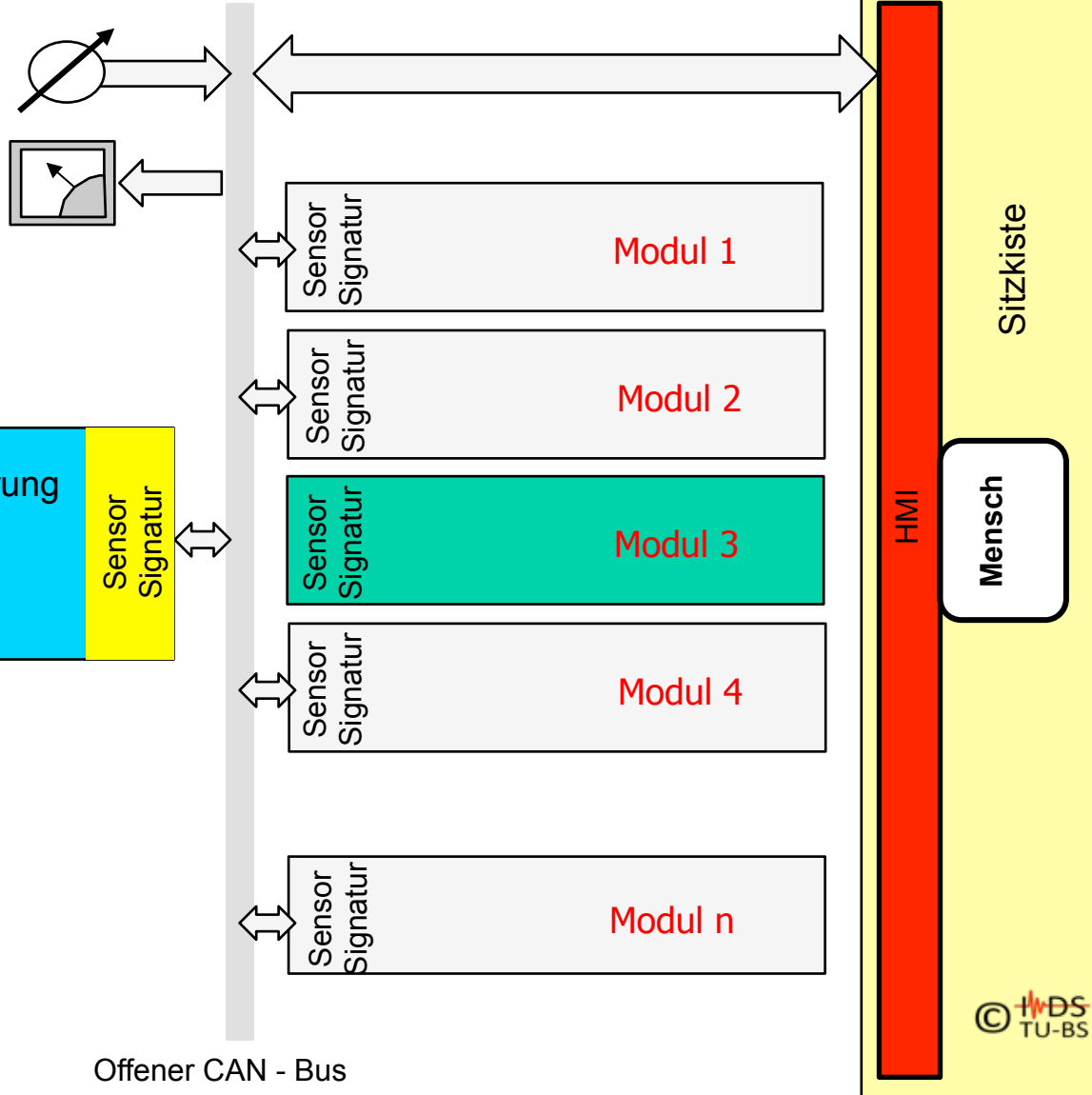
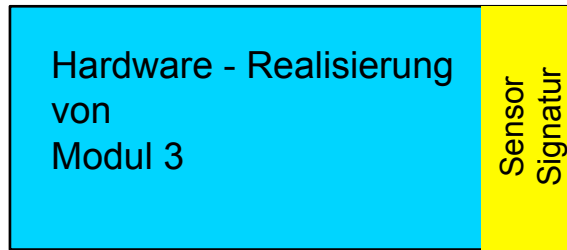

## „Hands On“ Simulators

CT



Dr.Dr.-Ing. C. Teodoriu  
Institute of Petroleum Engineering TU Clausthal



## „Hands On“ Simulators

CT



# The Drilling Autoclave Systems (DAS)

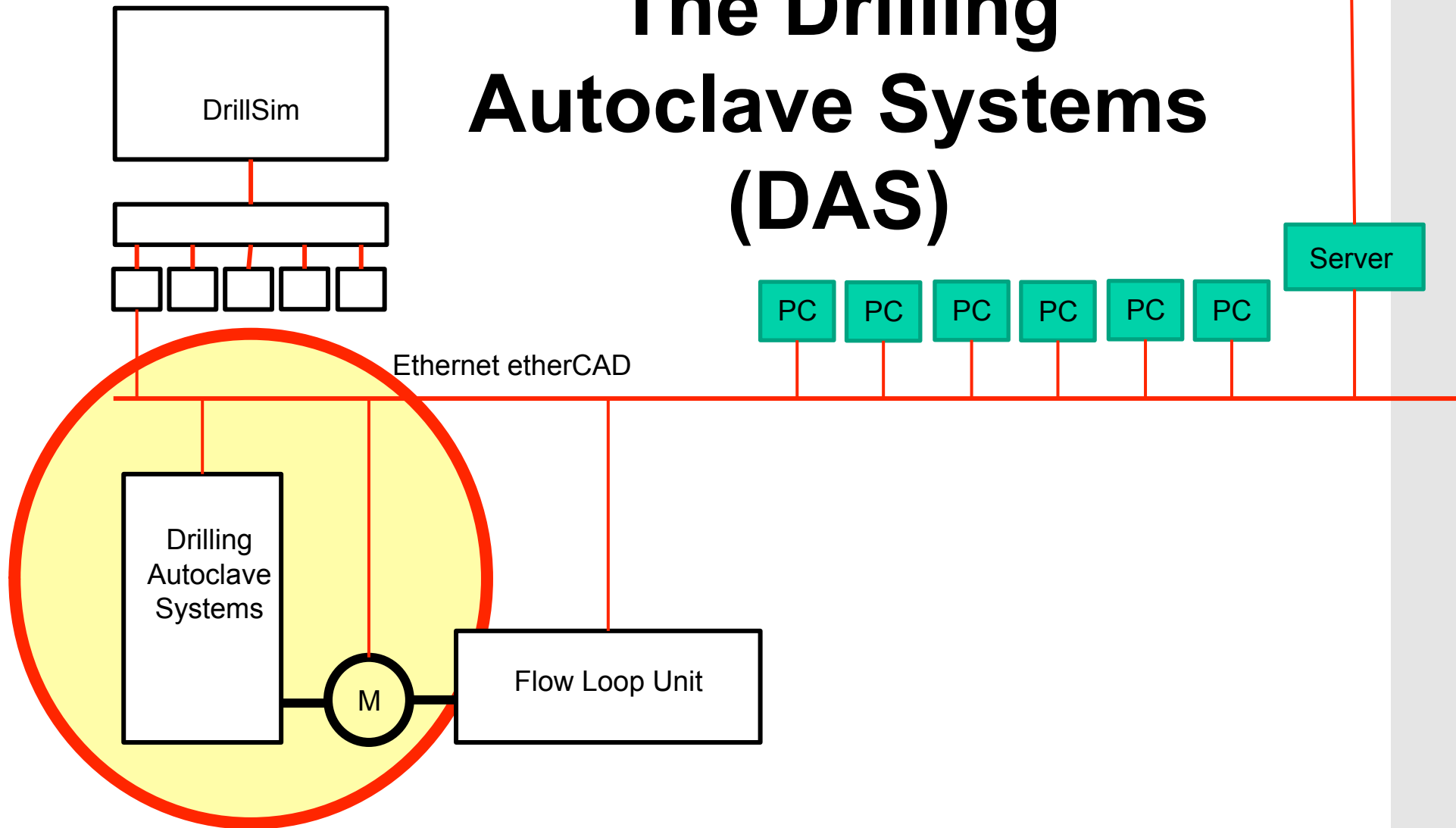

## DAS – worldwide concepts

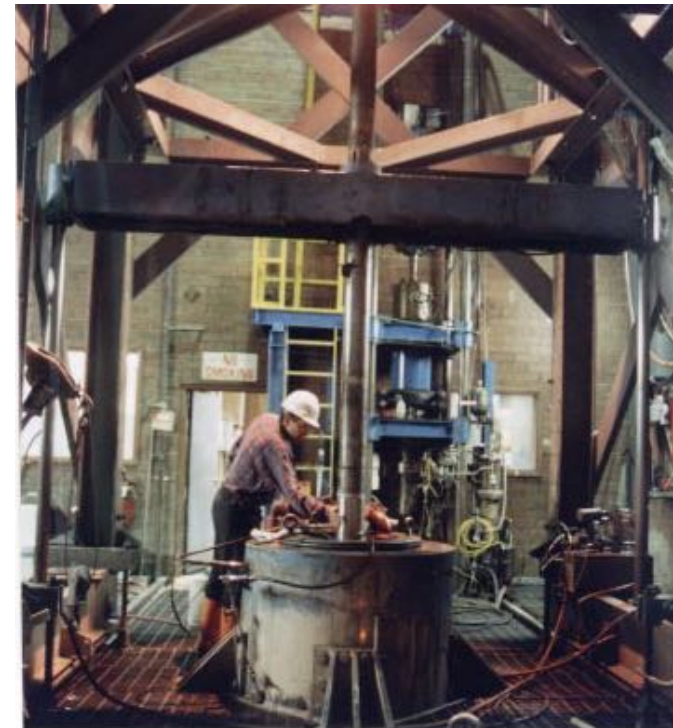
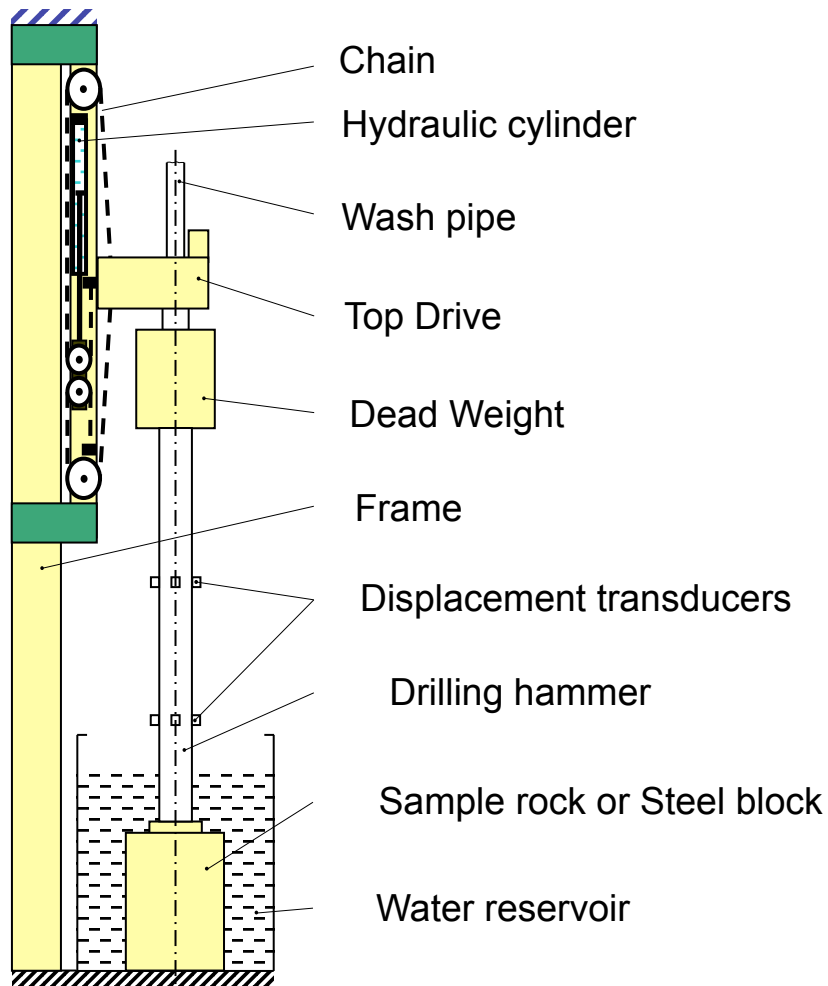

Terratek Drilling Autoclave

## ***DAS - Research Focus***

- Development of an intelligent bit concept to test various sensors and other bit features.
- Understanding of bit – rock interaction and standardization of testing setups.
- Mathematical description of bit-rock interaction.
- Testing of various bit types
- Testing of various hydraulic concepts for bits



## Overview of existing Rock-Bit interaction testing stands

1. Simulation

2. Single Cutter test

3. Small scale laboratory test

4. Full scale laboratory test

5. Field test

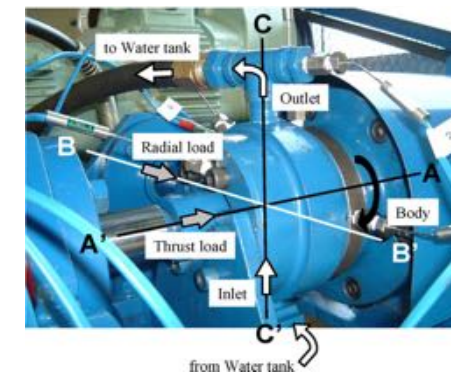
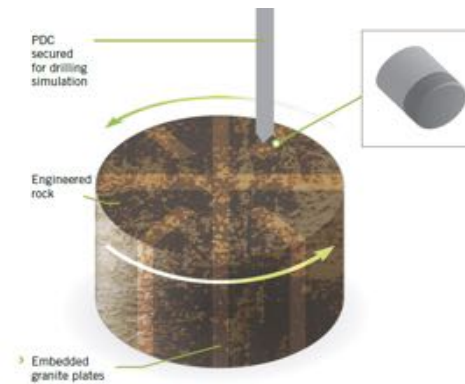
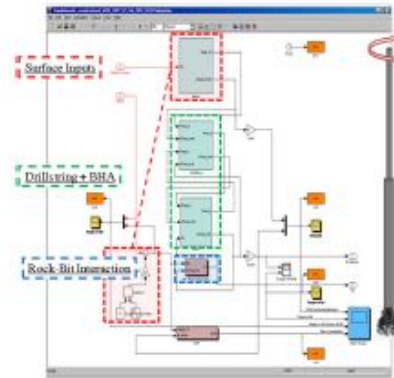

## Modeling and Simulation

- Theoretical analysis of PDC bit-rock interaction
- Proposed generalized equations for TOB and WOB
- Wear mechanism due to PDC bit-rock interaction

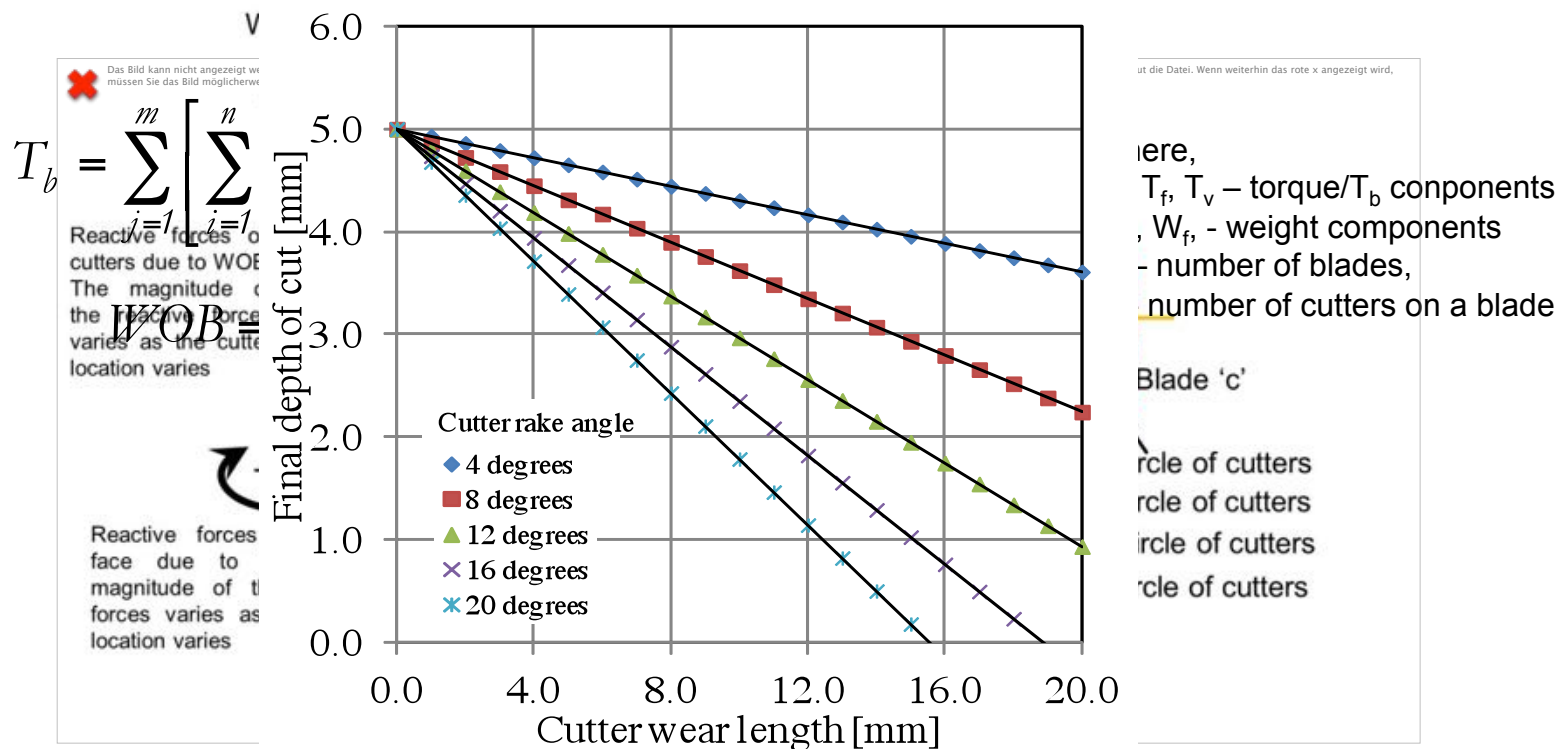

Patil and Teodoriu, 2013, Oil Gas European Magazine, Vol .3.  
 Patil and Teodoriu, 2013, DGMK/ÖGEW-Frühjahrstagung, Celle

## Testing and Comparing Drill Bits – a Challenge?

Testing vs. Comparing

*Chowdhury, BHI, IDEC 2011*



*Slb, Drill. Dyn. Sensors and Optimization, 2010*

## *Selected Testing facilities specifications*

	<b>A</b>	<b>B</b>	<b>C</b>	<b>D</b>	<b>E</b>	<b>G</b>	<b>H</b>
<b>WOB (k lbs)</b>	40	100	50	37	38	35	100
<b>Rotary Speed (RPM)</b>	100	240	500	1500	400	200	200
<b>Circulation rate (GPM)</b>	300	400	360	22	70	350	1000
<b>ROP (ft/hr)</b>	90	500	100	220	64	150	500
<b>TOB (ft-lb)</b>	750	10,000	5,000	405	750	2,250	10,000
<b>Rotary power (HP)</b>	60	1000	500	115	60	86	268
<b>Confining pressure (psi)</b>	9000	15,000	20000	N/A	N/A	N/A	15,000
<b>Overburden pressure (psi)</b>	12800	15,000	30000	N/A	3000	1000	20,000
<b>Borehole pressure</b>	N/A	10,000	2000	N/A	1395	N/A	10,000
<b>Max. Bit Size (in.)</b>	7 7/8	26	7 7/8	4 1/2	4 3/4	7 7/8	12 1/4

## *Main Parameters of a Multipurpose Testing Rig*

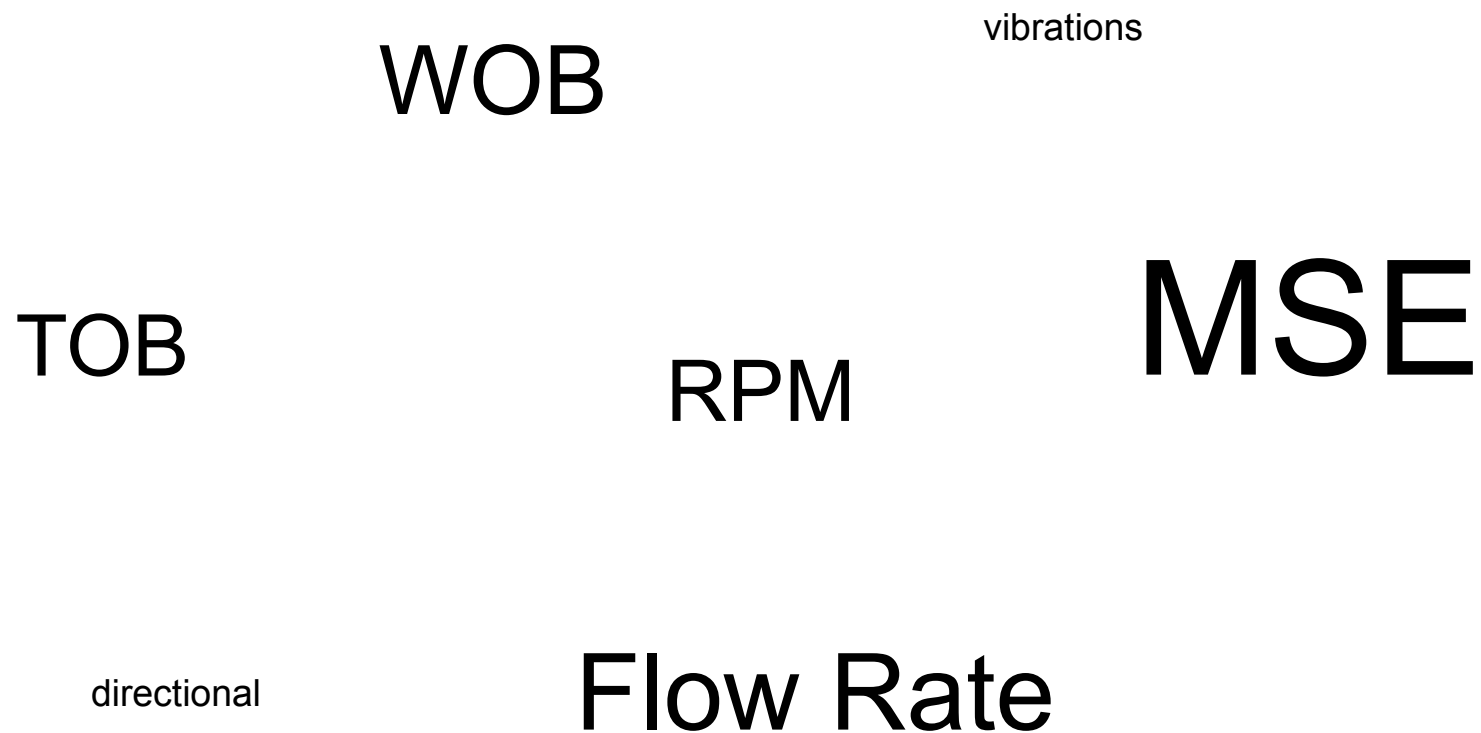



# MSE values for a PDC Bit after SPE 149372

		MSE - 916				
		100	120	140	180	200
Anhydrite	15	26871	33506	46470	46874	52970
	25	17740	17740	17582	17894	62054
	35	15563	15874	15961	16086	16540
	45	15247	15324	15329	15142	15597
	55	14862	14920	14979	15056	15123
Salt	15	18648	13533	15536	17240	17898
	25	14521	15280	15251	14885	15498
	35	13428	13490	13494	13601	13793
	45	12815	12868	12916	12986	13079
	55	12323	12408	12227	12489	12594
Limestone	15	13846	27541	31964	38881	44001
	25	15586	15759	15887	16005	15991
	35	13815	13383	13983	14102	14280
	45	13204	13273	13354	13408	13459
	55	12767	12816	12866	13002	13042
Sandstone	15	24943	25271	26202	26354	91647
	25	23214	23672	23880	24401	26037
	35	22405	22740	22768	23247	23503
	45	22008	22129	22341	22421	22598
	55	21183	21322	21525	21478	21781
Shale	15	46118	47456	48607	154069	192442
	25	44296	44580	52580	60852	71564
	35	35182	35312	35868	36009	36373
	45	31114	31287	31610	31678	32423
	55	28504	28755	28736	29166	29188
Dolomite	15	202702	265482	313585	348331	442016
	25	59894	62438	64568	65442	65011
	35	59312	60590	60436	61321	50635
	45	56311	57067	57047	49020	57794
	55	53636	53981	54546	54716	55070

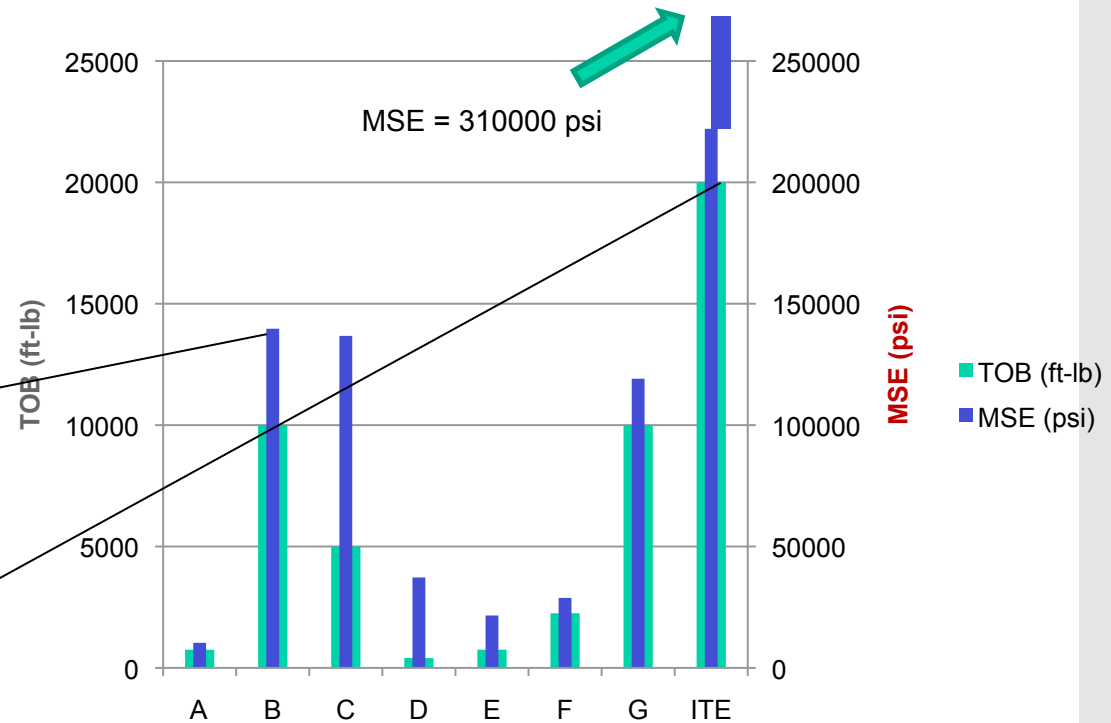

## The New Testing Facilities Specifications

	ITE Experimental Drilling Facility
<b>WOB (k lbs)</b>	120
<b>Rotary Speed (RPM)</b>	Max 120
<b>Circulation rate (GPM)</b>	~ 800
<b>ROP (ft/hr)</b>	500*
<b>TOB (ft-lb)</b>	Max 20000
<b>Rotary power (HP)</b>	~ 500
<b>Confining pressure (psi)</b>	7500 (upgradable)
<b>Overburden pressure (psi)</b>	7500 (upgradable)
<b>Borehole pressure (psi)</b>	7500 (upgradable)
<b>Max. Bit Size (in.)</b>	26
<b>MSE (psi)</b>	310 000
	*estimated values

## Schematic View of DAS

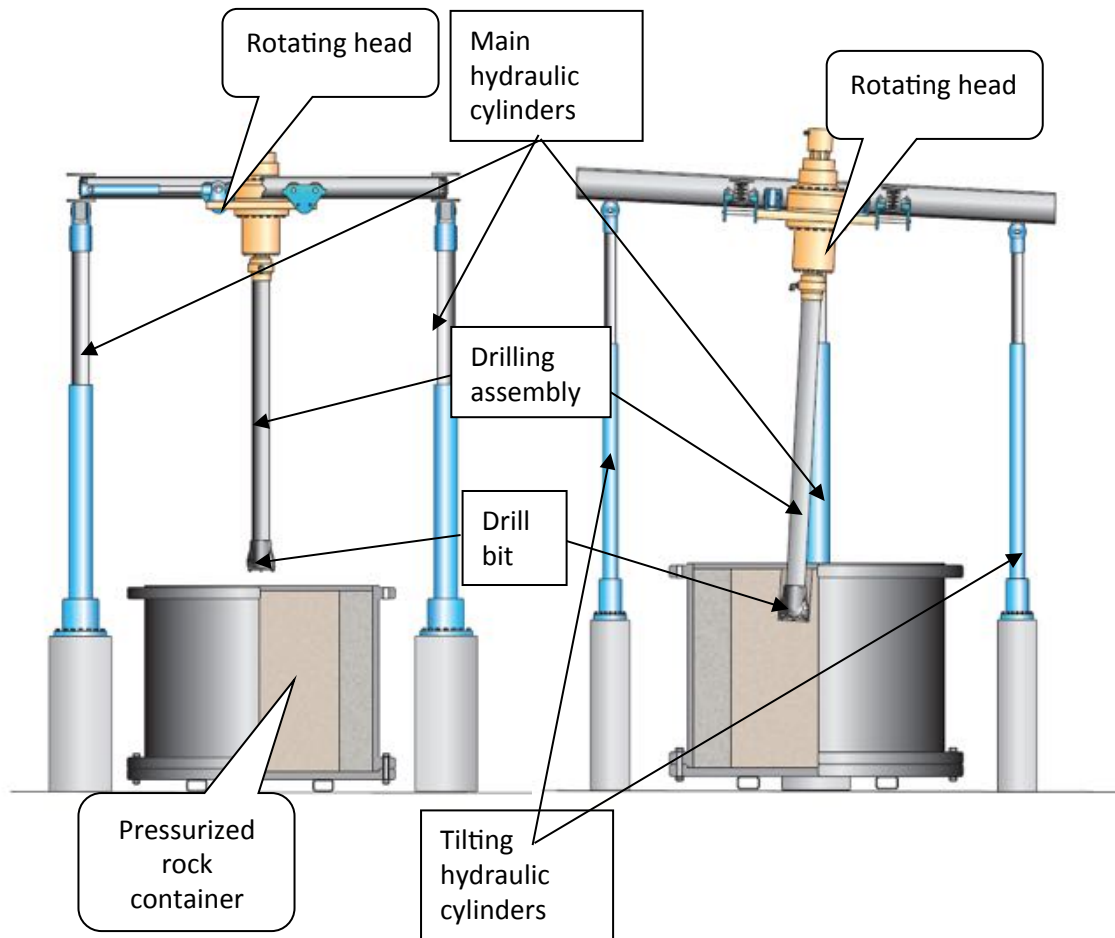



# Flow-loop Unit (FLU)

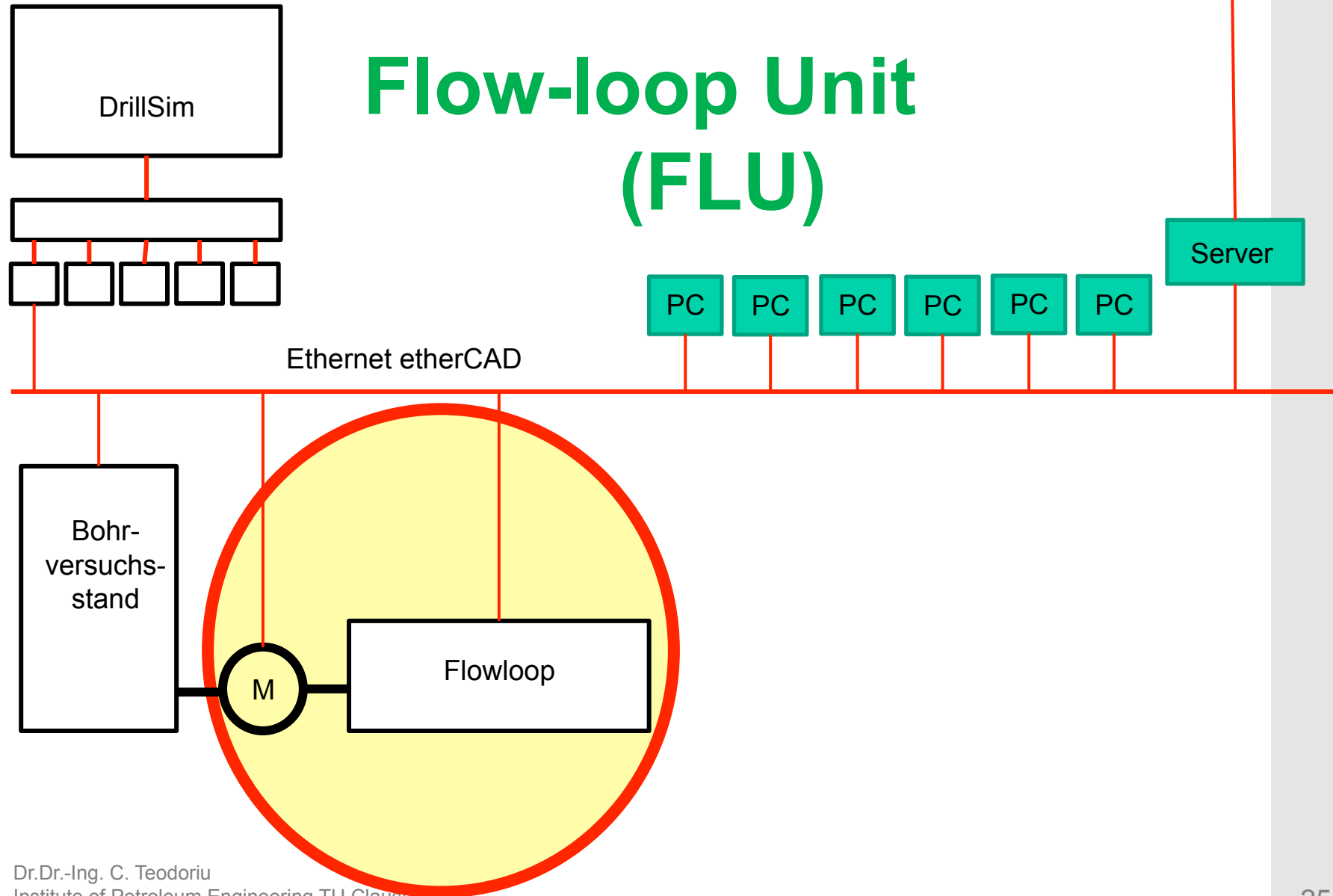

## FLU – Worldwide Concepts

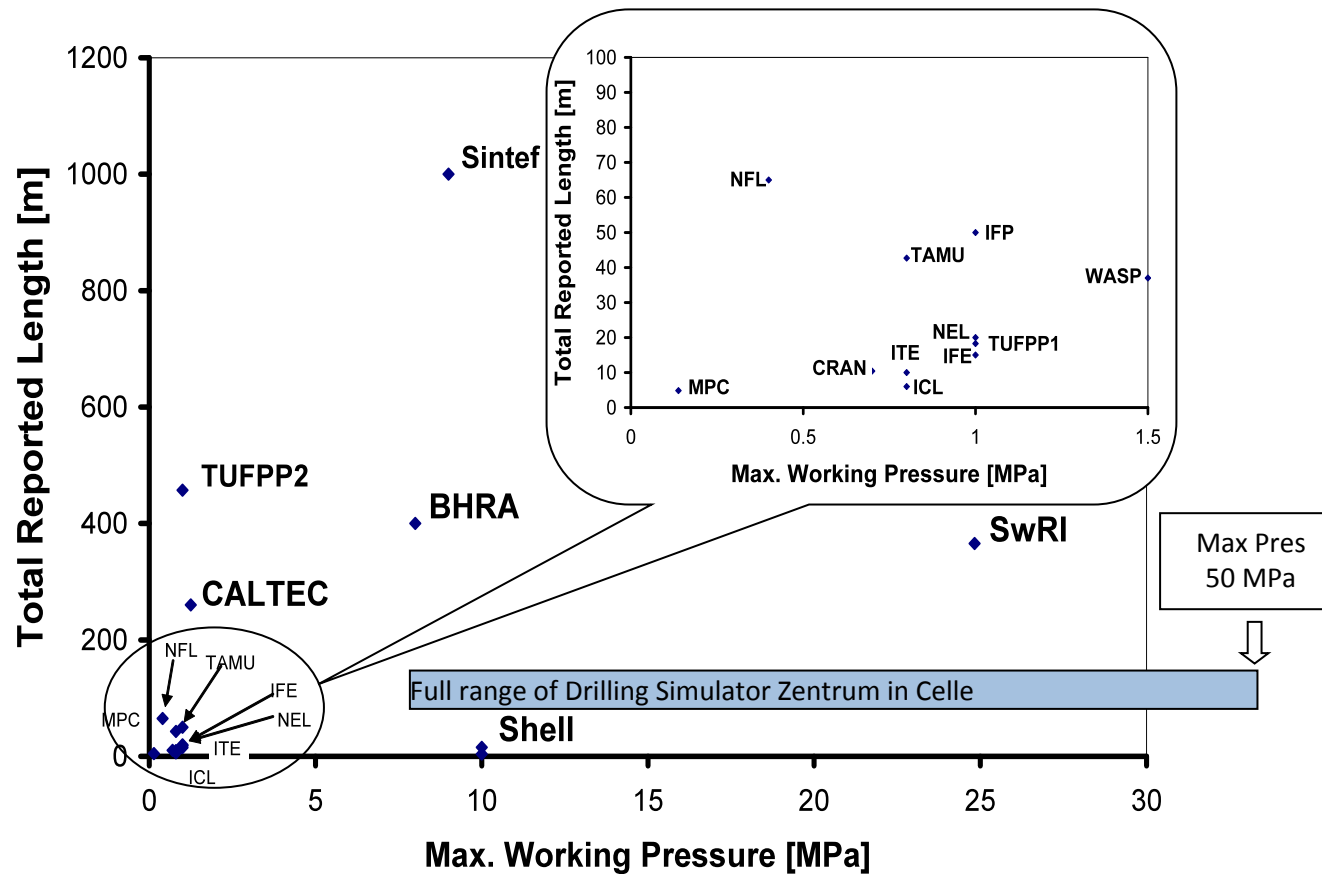

## The Flow Loop

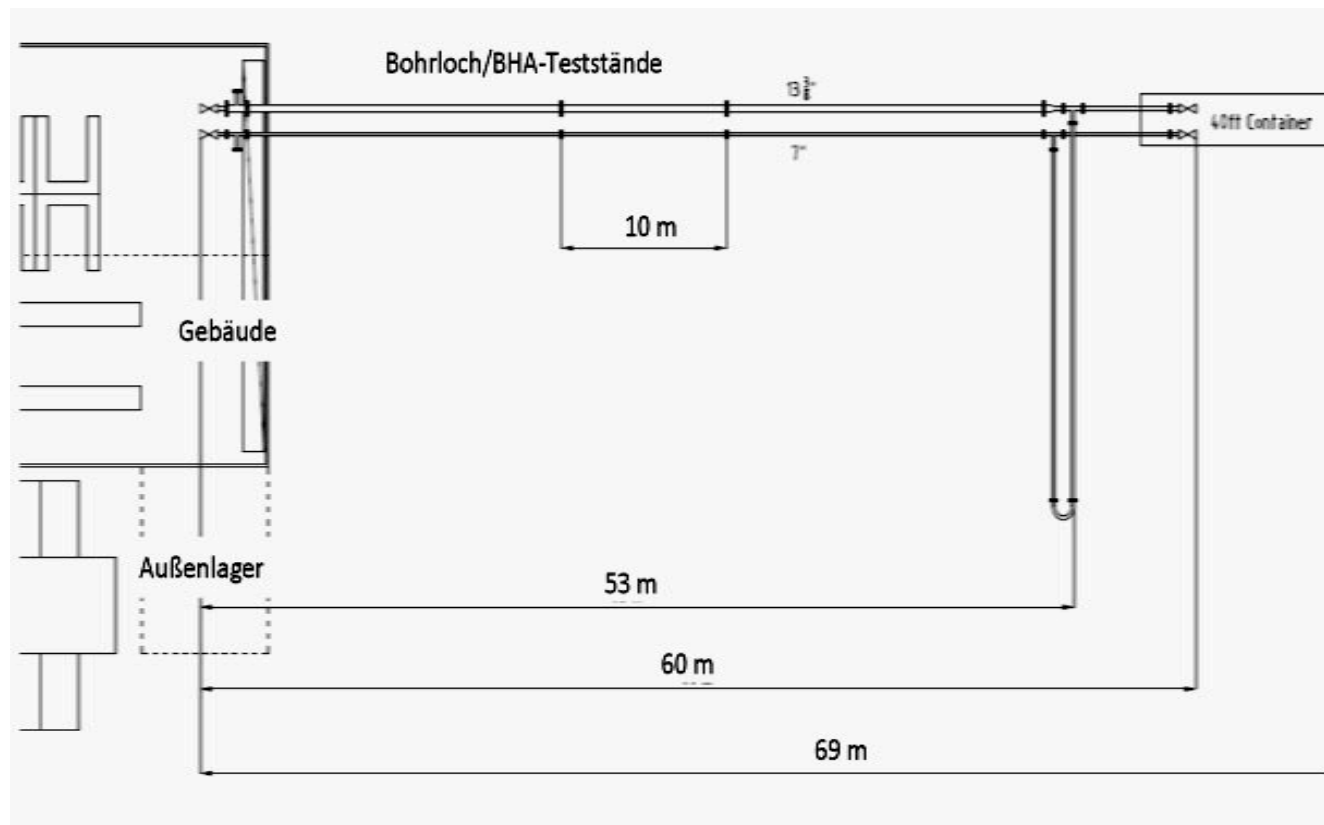

## The Flow Loop

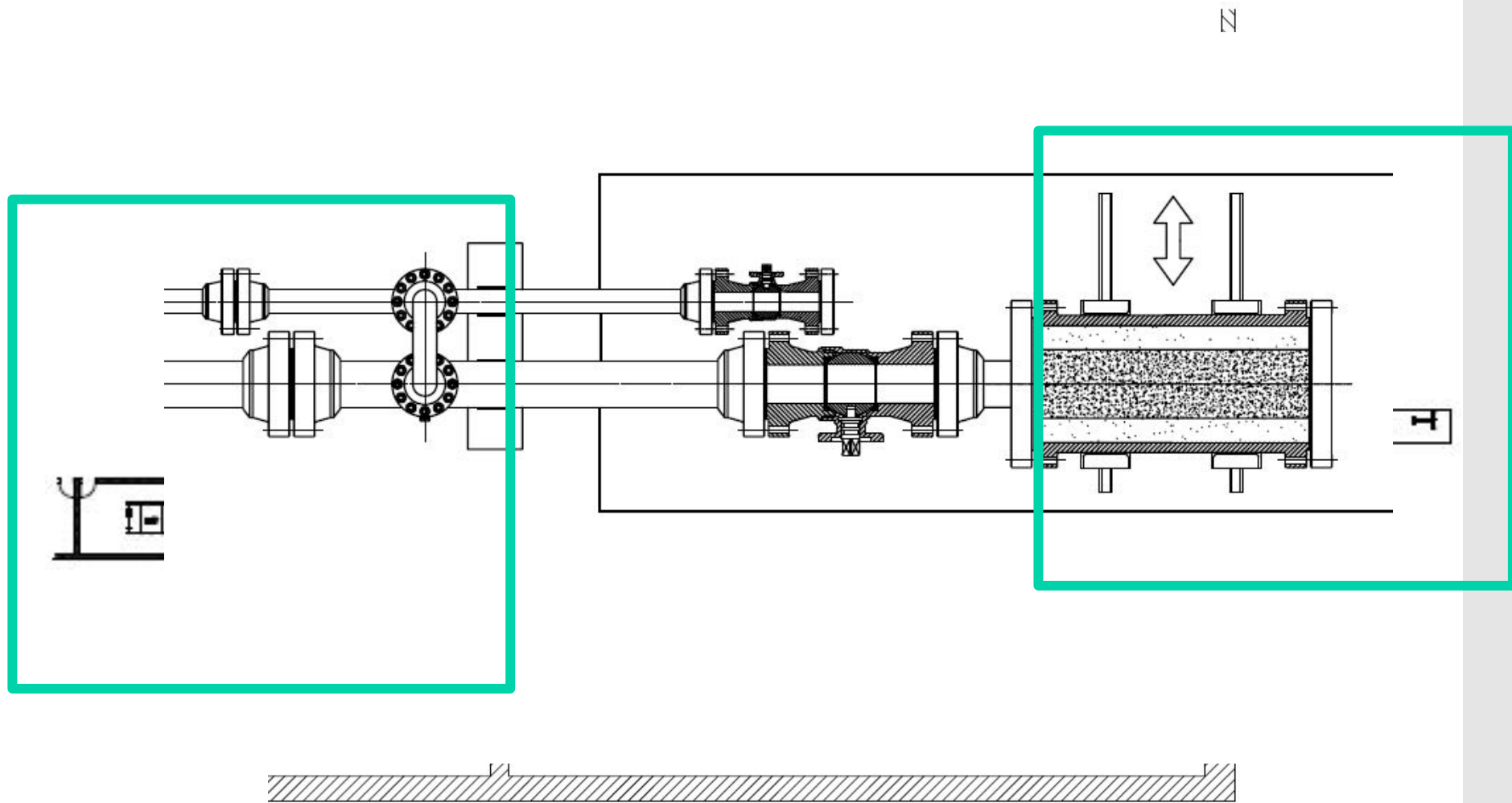

## The FLU Schematic

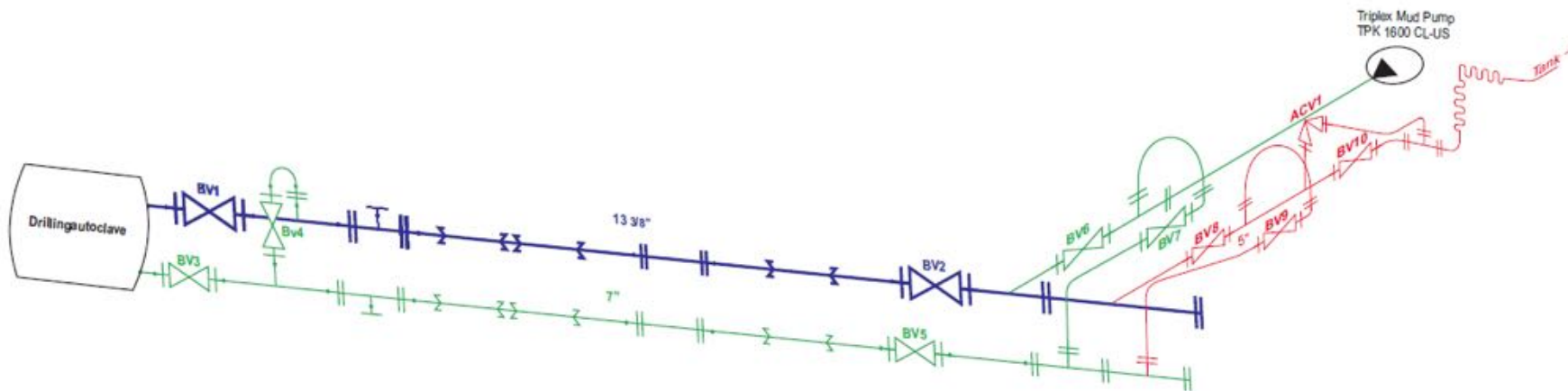



## *Flow Loop Description*

- Unique full size pumping system
- Pressure rating up to 500 bar
- Flow rate up to 3000 l/min
- Horizontal test section length ~70 m
- Total length upgradable to 300 m



Pump speed SPM	Max. input power kW
120	1193
110	1093
100	994
90	895
80	795
70	696
60	596
50	497
40	398
30	298
20	199



## *Research Focus*

- Perform fundamental research on hydraulic modeling for drilling fluids, especially under the consideration of downhole tools effect.
- Implement the pump as “Hardware in the Loop” into the DrillSim System, in order to simulate Transient Modes for the hydraulic system
- Testing of downhole tools under wellbore pressure conditions
- Testing of mud pumps and electric drivers under field loading conditions
- Testing of power control units (high power electronics)



## *Other Research Interests*

- High power electric systems (up to 1.2 MW) require attention, e.g. when continuous control is needed.
- Managed pressure drilling techniques involve continuous pump control.
- New electric control systems could allow the pump to perform better, while also reducing energy consumption.



## *The Flow Loop Components*

- Tanks and solids preparation units (shacker, hydrocyclons, etc)
- Flow loop itself
- Tool assembly line
- Mud pump
- Mud pump controlling unit
- Data Acquisition

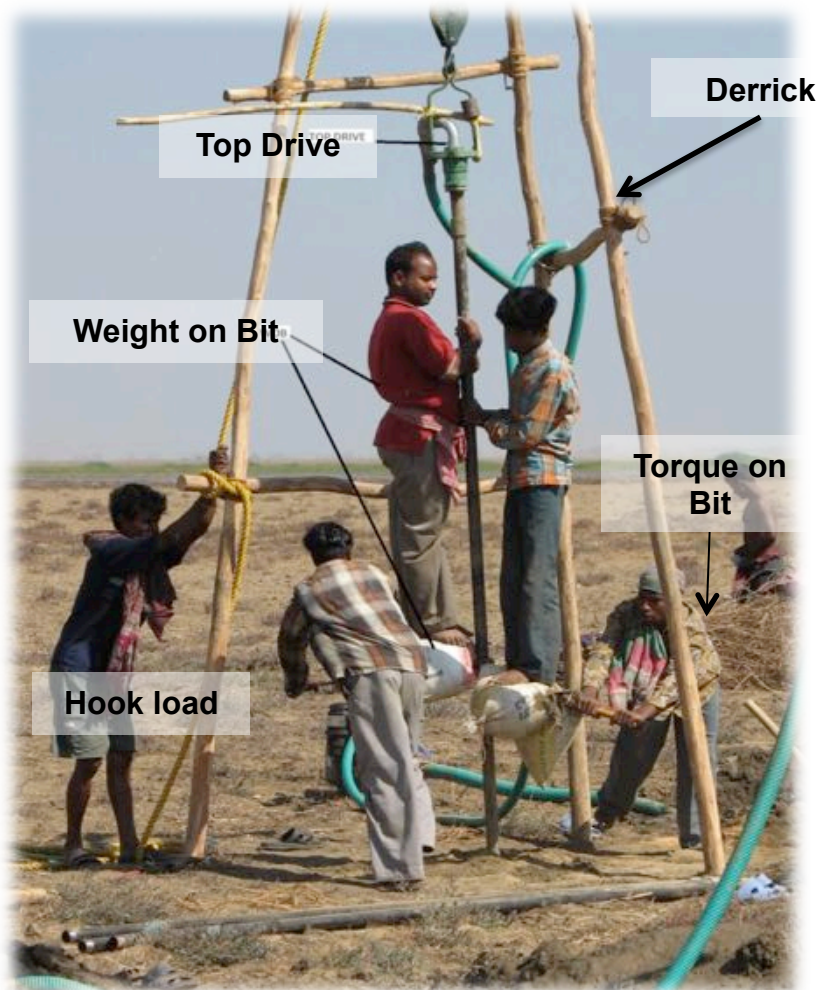

**Next STEP:**

**FIELD SCALE TESTING**

Thank you for  
your attention

## Drilling Simulator in Celle

**Contact:**

Catalin.Teodoriu@tu-clausthal.de